

# **TRANSDUCER T4311, T4411**

**Programmable temperature transducer for RTD  
Pt1000 sensor with serial output RS232 and RS485**

**Instruction manual**

© Copyright: COMET SYSTEM, Ltd.

It is prohibited to copy and make any changes in this manual, without explicit agreement of company COMET SYSTEM, Ltd. All rights reserved.

COMET SYSTEM, Ltd. makes constant development and improvement of their products. Manufacturer reserves the right to make technical changes to the device without previous notice. Misprints reserved.

Manufacturer is not responsible for damages caused by using the device in conflict with this manual.

To damages caused by using the device in conflict with this manual cannot be provide free repairs during the warranty period.

Carefully read instruction manual before the first device connection.

Contact address of this device's producer:

COMET SYSTEM, s.r.o.  
Bezrucova 2901  
756 61 Roznov pod Radhostem  
Czech Republic  
[www.cometsystem.com](http://www.cometsystem.com)

# Instruction Manual for use of transducer: T4311 (RS232), T4411 (RS485)

Transducer is designed for temperature measurement at °C or °F by means of the external temperature probe with RTD Pt1000 sensor. It is built in a plastic case with the IP65 protection. Read this manual before the first transducer connection. Transducer T4311 communicates via link RS232, transducer T4411 via link RS485. Supported communication protocols are Modbus RTU, protocol compatible with standard Advantech-ADAM, ARION and communication with HWg–Poseidon devices. Measured value is displayed on dual line LCD display. Display can be also switched OFF. Output link RS485 of transducer T4411 is **galvanic isolated**. Output link RS232 of transducer T4311 is **NOT** galvanic isolated.

Use user's software *TSensor* for setting of all device parameters (recommended). It is free to download at [www.cometsystem.com](http://www.cometsystem.com). It supports make the adjustment of the device too. This procedure is described at the file „*Calibration manual.pdf*“ which is installed commonly with the software. Change of some parameters is possible to do without user's software with Windows hyperterminal (change of communication protocol, its parameters, LCD display setting). It is described in file “*Description of communication protocols of Txxxx series*” which is free to download at the same address.

**Transducer version TxxxxL** with watertight male connector instead of a cable gland (RS232) or glands (RS485) is designed for easy connection/disconnection of communication cable. Male Lumberg connector RSFM4 has protection IP67.

**Models marked TxxxxZ** are non-standard versions of the transducers. Description is not included in this manual.

**Please read instruction manual before the first device connection.**

## Transducer setting from the manufacturer

If special setting was not required in the order, transducer is set from the manufacturer to the following parameters:

communication protocol:	<b>Modbus RTU</b>
transducer address:	<b>01H</b>
communication speed:	<b>9600Bd, no parity, 2 stop bits</b>
display:	<b>switched ON</b>

## Transducer installation

Transducer is designed for wall mounting. There are two mounting holes at the sides of the case. Don't connect device while power supply voltage is on. Interconnection terminals for T4311 and T4411 devices are accessible after unscrewing four screws and removing the lid. Lace the cable through a gland at the case wall. Connect the cable to terminals with respecting the signal polarity (see figure). Terminals are self-clamping and can be opened by a suitable screwdriver. For the opening, insert the screwdriver to smaller terminal hole and lever by him. Do not forget to tighten glands and case lid with inserted packing after cables connecting. It is necessary for warranting of protection IP65. Connect complementary female connector for T4311L and T4411L transmitters in accordance with the table in Appendix B of this manual. Working position is negligible.

External temperature probe should be of „shielded two-wire“ type. For leading of the cable same recommendations are valid as for current loop cable, i.e. cable should be located as far as possible from potential interference sources. Maximum probe cable length is 10 m. Connect probe cable shielding to proper terminal and do not connect it to any other circuitry and do not ground it. If connected probe is equipped with metal stem, we recommend to use probes with metal stem not

connected to cable shielding. Or else it is necessary to arrange metal stem is not connected to any other circuitry.

Devices T4311 are supplied with connection cable equipped with connector for connection to RS232 interface. For devices with RS485 output there is recommended to use shielded twisted copper cable, maximal length 1200m. The cable must be located at indoor rooms. Nominal cable impedance should be 100  $\Omega$ , loop resistance max. 240  $\Omega$ , cable capacity max. 65 pF/m. Outside diameter of the cable for T4411 connection must be from 3 to 6.5 mm. Suitable cable is e.g. SYKFY 2x2x0.5 mm<sup>2</sup>, where one wire pair serves for device powering and the other pair for communication link. For devices T4311L and T4411L use cable with respect to female connector parameters. Do NOT connect shielding at connector side.

The cable should be led in one line, i.e. NOT to „tree“ or „star“. Termination resistor should be located at the end. For short distance other topology is allowed. Terminate the network by a termination resistor. The value of the resistor is recommended about 120  $\Omega$ . For short distance termination resistor can be left out.

The cable should not be led in parallel along power cabling. Safety distance is up to 0.5 m, otherwise undesirable induction of interference signals can appear.

Electrical system (wiring) may do only worker with required qualification by rules in operation.

## Dimensions – T4311

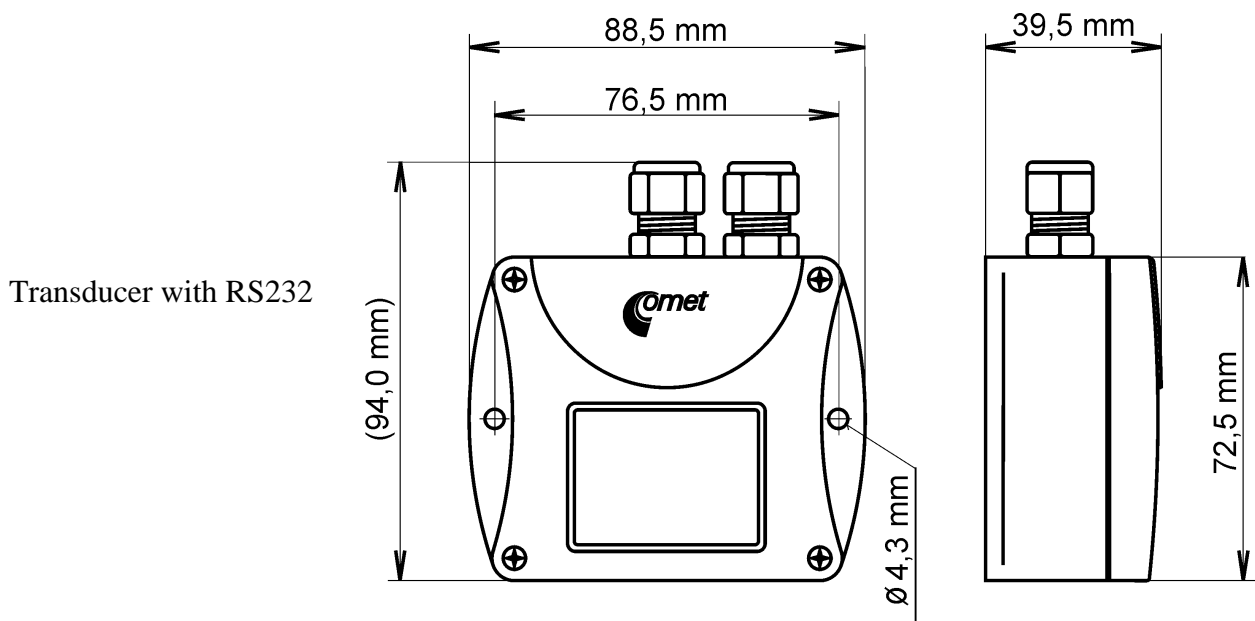

## Dimensions – T4411

Transducer with RS485

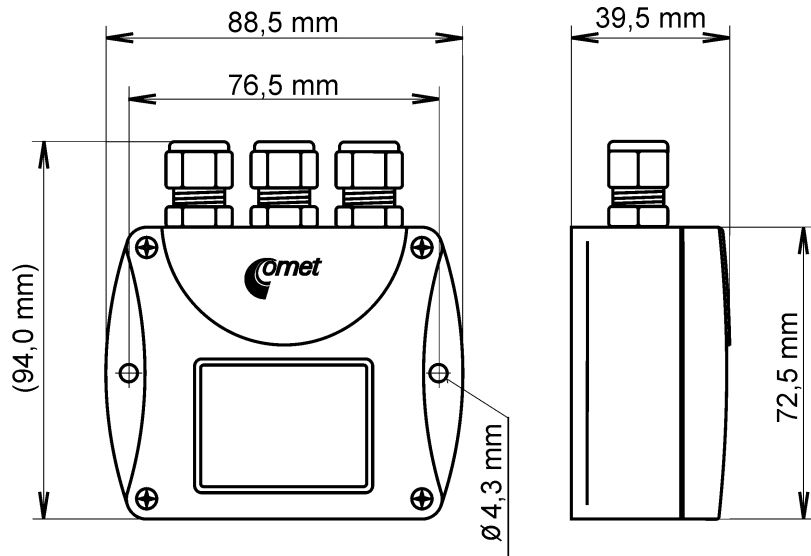

## Dimensions – T4311L, T4411L

Connection: see Appendix B

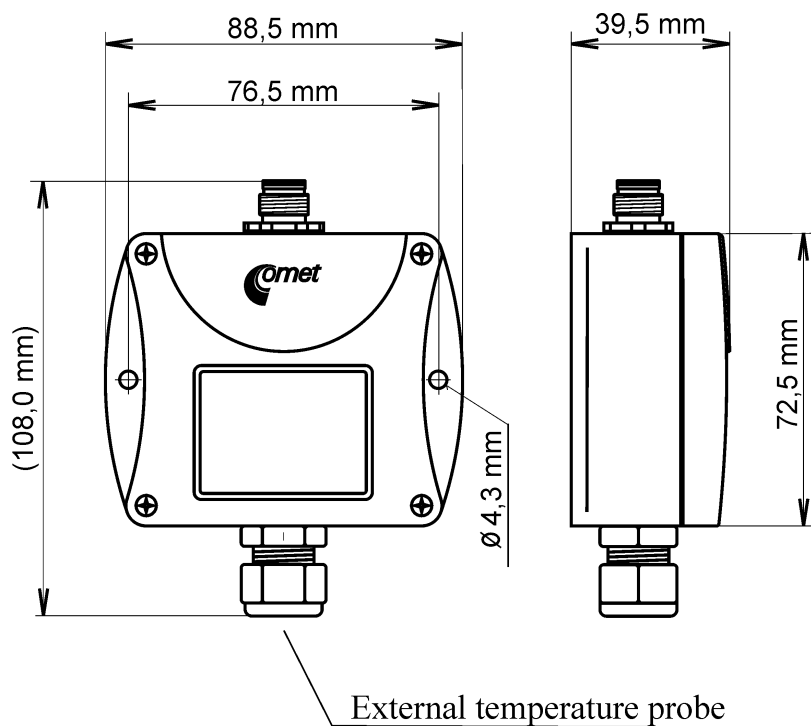

# Typical application wiring, connection of terminals

**T4311 – power from communication port**

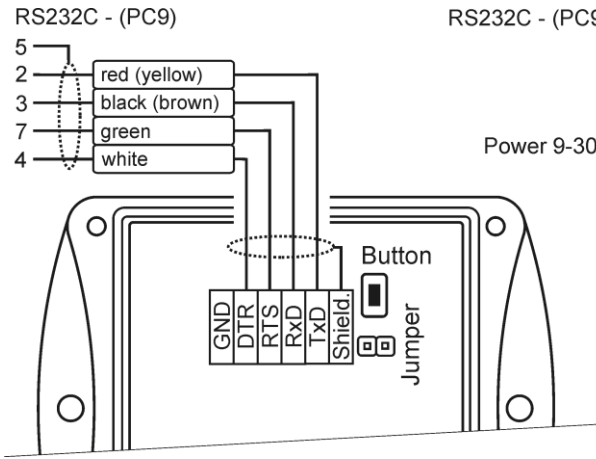

**T4311 – power from external voltage source**

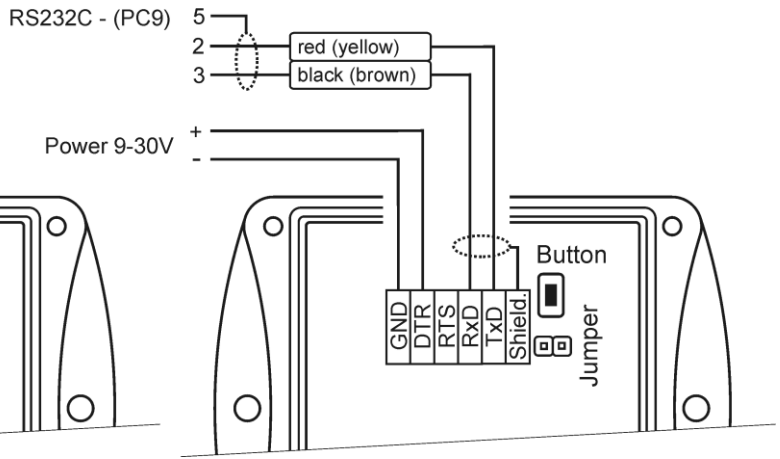

**T4411 – RS485**

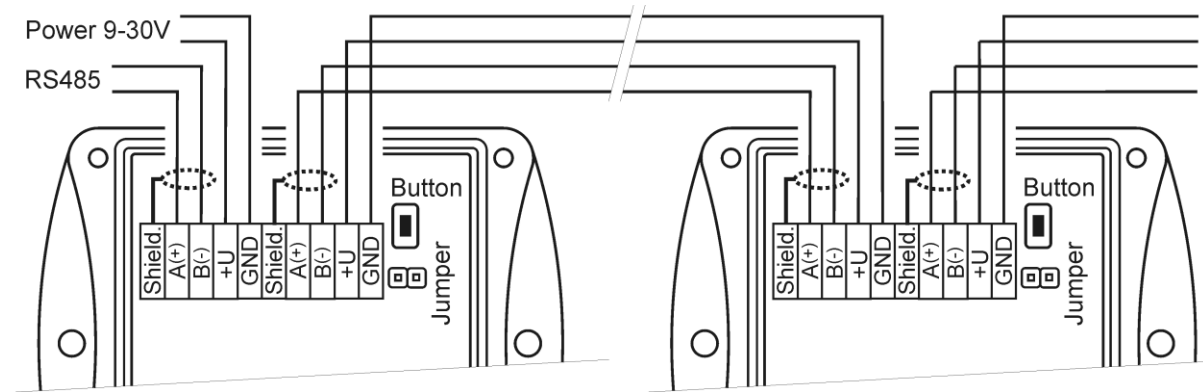

## Info mode

If in doubt of setting of installed transducer, verification of its address is enabled even without using computer. Power should be connected.

Unscrew transducer cover and shortly press button next to connection terminals (jumper must be open). Actual adjusted address of transducer is displayed on LCD display at decimal base, for HWg-Poseidon's communication protocol there is shown number corresponding with ASCII address code. Next press of button exits info mode and actual measured values are displayed.

Note: No measurement and communication is possible during info mode. If transducer stays in info mode for longer than 15 s, transducer automatically returns to measuring cycle.

## Description of communication protocols

Detailed description of each communication protocols including examples of communication is available in individual document "*Description of communication protocols of Txxxx series*" which is free to download at [www.cometsystem.com](http://www.cometsystem.com).

Note: After switching ON the power of the device it can last up to 2 s before the device starts to communicate and measure!

## Modbus RTU

Control units communicate on master-slave principle in half-duplex operation. Only master can send request and only addressed device responds. During sending of request no other slave station should respond. During communication, data transfer proceeds in binary format. Each Byte is sent as eight bit data word in format: 1 start bit, data word 8 bit (LSB first), 2 stop bits<sup>1</sup>, without parity. Transmitter supports communication speed from 110Bd to 115200Bd.

Sent request and response have syntax: ADDRESS OF DEVICE – FUNCTION – Modbus CRC

## Supported functions

**03 (0x03):** Reading of 16-bit registers (Read Holding Registers)

**04 (0x04):** Reading of 16-bit input gates (Read Input Registers)

**16 (0x10):** Setting of more 16-bit registers (Write Multiple Registers)

## Jumper and button

Jumper and button are located next to connection terminals. If communication protocol Modbus is selected the function of jumper and button is as follows:

- Jumper opened – transmitter memory is protected from writing, from transmitter side it is only enabled to read measured value, writing to memory is disabled (no change of transmitter address, communication speed and LCD setting is enabled).
- Jumper closed – writing to transmitter memory is enabled by means of User's software.
- Jumper closed and button pressed for longer than six seconds – causes restoring of manufacturer setting **of communication protocol**, i.e. sets Modbus RTU communication protocol, device address sets to 01h and communication speed to 9600Bd - after button press there is "dEF" message blinking at LCD display. Six seconds later message "dEF" stays shown, it means manufacturer setting **of communication protocol** is done.
- Jumper opened and button shortly pressed – transmitter goes to Info mode, see chapter „*Info mode*“.

---

<sup>1</sup> Transmitter sends two stop bits, for receive one stop bit is enough.

## Modbus registers of the device

Variable	Unit	Address [hex] <sup>x</sup>	Address [dec] <sup>x</sup>	Format	Size	Status
Measured temperature	[°C]	0x0031	49	Int*10	BIN16	R
Address of transmitter	[-]	0x2001	8193	Int	BIN16	R/W*
Code of communication speed	[-]	0x2002	8194	Int	BIN16	R/W*
Serial number of transmitter Hi	[-]	0x1035	4149	BCD	BIN16	R
Serial number of transmitter Lo	[-]	0x1036	4150	BCD	BIN16	R
Version of Firmware Hi	[-]	0x3001	12289	BCD	BIN16	R
Version of Firmware Lo	[-]	0x3002	12290	BCD	BIN16	R

### Explanation:

- Int\*10 register is in format integer\*10
- R register is designed only for reading
- W\* register is designed for writing, for more details see chapter description of communication protocols
- <sup>x</sup> register addresses are indexed from zero – register 0x31 is physically sent as value 0x30, 0x32 as 0x31 (zero based addressing)

**Note:** In case there is a need for reading of measured values from transmitter with higher resolution than one decimal, measured values in transmitter are stored also in „Float“ format, which is not directly compatible with IEEE754.

## Protocol compatible with Advantech-ADAM standard

Control units communicate on master-slave principle in half-duplex operation. Only master can send requests and only addressed device responds. During sending request any of slave devices should respond. During communication data is transferred in ASCII format (in characters). Each Byte is sent as two ASCII characters. Transmitter supports communication speed from 1200Bd to 115200Bd, parameters of communication link are 1 start bit + eight bit data word (LSB first) + 1 stop bit, without parity.

### Jumper

Jumper is located next to connection terminals. If communication protocol compatible with standard Advantech-ADAM is selected, its function is the following:

- If jumper during switching ON the power is closed, transmitter always communicates with following parameters regardless stored setting in the transmitter: communication speed 9600 Bd, without check sum, transmitter address 00h
- If jumper during switching ON the power is not closed, transmitter communicates in accordance with stored setting.
- If jumper is closed during transmitter operation, transmitter temporarily changes its address to 00h, it will communicate in the same communication speed as before closing jumper and will communicate without check sum. After jumper is opened setting of address and check sum is reset in accordance with values stored in transmitter.
- Communication speed and check sum are possible to change only if jumper is closed.
- Jumper closed and button pressed for longer than six seconds – causes restoring of manufacturer setting **of communication protocol**, i.e. sets Modbus RTU communication protocol, device address sets to 01h and communication speed to 9600Bd - after button press there is “dEF” message blinking at LCD display. Six seconds later message “dEF” stays shown, it means manufacturer setting **of communication protocol** is done.



## ARION communication protocol - AMiT company

The device supports communication protocol ARiON version 1.00. For more details see file “Description of communication protocols of Txxxx series” or [www.amit.cz](http://www.amit.cz).

### Communication with HWg Poseidon units

Device supports communication with HWg-Poseidon units. For communication with this unit set the device with setup software TSensor to communication protocol HWg–Poseidon and set correct device address. This communication protocol supports read temperature at °C, relative humidity, one of computed value (dew point temperature or absolute humidity) and barometric pressure at kPa (depended by device type). For atmospheric pressure correction to altitude setting there is Users software TSensor.

### Jumper and button

If communication with HWg Poseidon unit is selected, the function of jumper and button is as follows:

- Jumper opened and button shortly pressed – device goes to Info mode, see chapter „Info mode“.
- Jumper closed and button pressed for longer than six seconds – causes restoring of manufacturer setting **of communication protocol**, i.e. sets Modbus RTU communication protocol, device address sets to 01h and communication speed to 9600Bd - after button press there is “dEF” message blinking at LCD display. Six seconds later message “dEF” stays shown, it means manufacturer setting **of communication protocol** is done.

## Error states of the device

Device continuously checks its state during operation. In case error is found LCD displays corresponding error code:

### Error 0

First line displays „Err0“.

Check sum error of stored setting inside device’s memory. This error appears if incorrect writing procedure to device’s memory occurred or if damage of calibration data appeared. At this state device does not measure and calculate values. It is a serious error, contact distributor of the instrument to fix.

### Error 1

Measured value is over upper limit of allowed full scale range. There is a reading „Err1“ on LCD display. This state appears if measured temperature is higher than approximately 600 °C (i.e. high non-measurable resistance of temperature sensor, probably opened circuit).

### Error 2

There is a reading „Err2“ on LCD display. Measured value is below lower limit of allowed full scale range. This state appears if measured temperature is lower than approximately -210 °C (i.e. low resistance of temperature sensor, probably short circuit).

## Error 3

There is a reading „Err3“ on LCD display upper line.

Error of internal A/D converter appeared (converter does not respond, probably damage of A/D converter). No measurements proceed. It is a serious error, contact distributor of the instrument.

## Readings on LCD display

°C, °F

Reading next to this symbol is measured temperature or error state of value.

symbol **3** near by left display margin

Is on if jumper is closed.

## Technical parameters of the instrument:

### RS 485 Interface:

Receiver-Input Resistance: 96 k $\Omega$

Devices on bus: max. 256 (1/8 Unit Receiver Load)

### Measuring parameters:

**Temperature probe:** Pt1000/3850 ppm connected by shielded cable of maximum length 10m

**Measuring temperature range:** -200 to +600 °C (can be limited by applied temperature probe model)

**Resolution:** 0.1 °C

**Accuracy (without probe):**  $\pm 0.2$  °C

**Recommended calibration interval:** 2 years

**Measuring interval and LCD display refresh:** 0.5 s

**Power:** 9 to 30 V dc **rotection:** IP65

### Operating conditions:

Operating temperature range: -30 to +80 °C, over +70°C switch LCD display OFF

Operating relative humidity range: 0 to 100 %RH

Outer influence in accordance with Czech National Standard 33-2000-3:

normal environment with those specifications: AE1, AN1, AR1, BE1

Working position: negligible

Electromagnetic compatibility: complies EN 61326-1

### Not allowed manipulation

It is not allowed to operate the device under conditions other than specified in technical parameters. Devices are not designed for locations with chemically aggressive environment.

**Storing conditions:** temperature -30 to +80 °C, humidity 0 to 100 %RH without condensation

**Dimensions:** see dimensional drawings

**Weight:** approximately T4311 215 g, T4311L 145 g, T4411(L) 145 g

**Material of the case:** ASA

## **End of operation**

Device itself (after its life) is necessary to liquidate ecologically!

## **Technical support and service**

Technical support and service is provided by distributor. For contact see warranty certificate.

## Appendix A

### Connection of transmitters with RS485 output to the PC

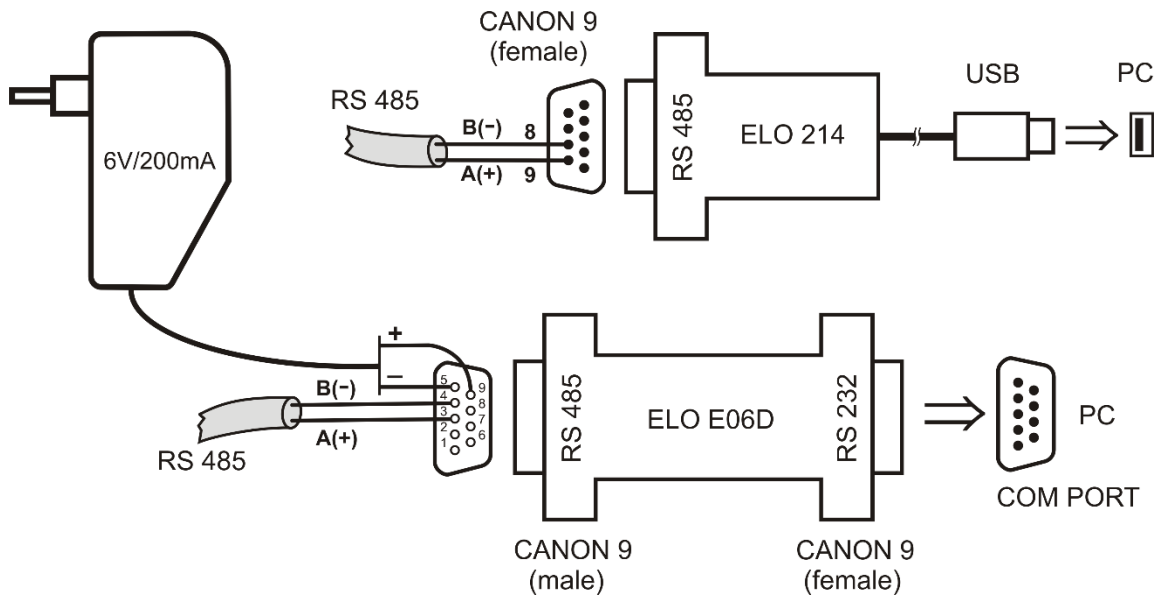

To connect a transmitter with an RS485 interface to a computer, you can use a suitable commercially available converter. Connect the converter according to the converter's manual. In case of communication problems, check whether it is necessary to configure the resistor connections for defining the idle state, the termination resistor or the time delay. The above figure shows examples of connection using the ELO E214 converters (connects to the computer's USB interface) and ELO E06D (for a computer with an RS232 interface).

## Appendix B

Female Lumberg connector	Transmitter Tx1xxL with 4-20mA outputs	Transmitter Tx2xxL with 0-10V outputs	Transmitter Tx3xxL with RS232 output	Transmitter Tx4xxL with RS485 output
1	+I1	Udd	RTS	+U
2	+I2	Uout1	Rx	A
3	-I2	Uout2	Tx	B
4	-I1	GND	GND	GND